

## 52

### Innv. lim/inv./utv. gjenge

- Innvendig lim
- Inklusiv pakning i Hypalon eller Viton
- PN 10

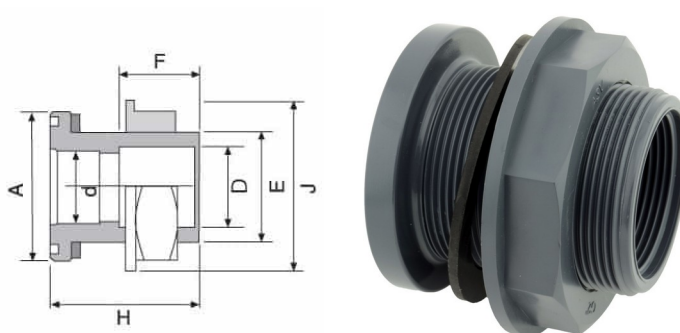

Artikkelnr	NRF	d	A	D	E	F	H	J	Pakning
52336	2445323	16	36	R 3/8"	R 3/4"	17	40	36	CSM
52337	2445325	20	50	R 1/2"	R 1"	18	45	50	CSM
52338	2445327	20	50	R 3/4"	R 1"	18	45	50	CSM
52339	2445329	25	60	R 1"	R 1 1/4"	23	60	60	CSM
52340	2445332	40	80	R 1 1/2"	R 2"	40	74	93	CSM
52341	2445334	63	110	R 2"	R 2 3/4"	40	80	110	CSM
52342		16	36	R 3/8"	R 3/4"	17	40	36	FPM
52343		20	50	R 1/2"	R 1"	18	45	50	FPM
52344		20	50	R 3/4"	R 1"	18	45	50	FPM
52345		25	60	R 1"	R 1 1/4"	23	60	60	FPM
52346		40	80	R 1 1/2"	R 2"	40	74	93	FPM
52347		63	110	R 2"	R 2 3/4"	40	80	110	FPM