

# Offshore Type Lined Butterfly Valve / 108LAVD



# Offshore Type Lined Butterfly Valve 108LAV

Teflonlined valves – where performance as well as costs are in focus

## Why use teflon?

- No risk for corrosion
- Cheaper than metal valves especially Titanium and Super-duplex Valves
- No problems with fouling in seawater systems
- Low valve torques

## XOMOX fully lined butterfly valve type 108LAV

A cost effective solution for corrosive applications replacing expensive high alloy valves.

Two-piece robust design for higher pressure applications. Equipped with high-tensile shaft and bearing materials.

- No "dead space" internal in the valve and therefor no risk for salt-crystallization
- Blow-out proofed one-piece disc-stem design fully rated acc. to ANSI CL 150 (PN20)
- Approved to NORSOK standard and TR2000
- Excellent references at seawater applications
- Sizes from NPS 3-24.
- Temperature -29°C to +180 °C
- Lining material: PFA and PTFE
- Face to face dimension: API 609
- Disc/Shaft material: 1.6982+QT/ PFA
- Standard supplied with paint according to TR0042, RAL 9002, others on request
- Have successfully passed the cycle test required by Statoil
- Successfully performed fire test acc. to API 607, 4th edition
- More than 17 years experience in operation offshore!
- Stock at GPA Ski, outside Oslo in sizes 3"-12"

# 108LAV

The valve combines strength with full protection against corrosion and is especially developed for seawater service in offshore applications

## Pressure range

Suitable for vacuum service (1,33 hPa)  
Standard operating pressure max. 20 bar

## Design temperature

-29°C up to 180°C (-20°F up to 356 °F)

## ISO 5211 Mounting Pad

allows the option of bracket or direct mounting of operators. Direct mounting ensures robust performance while providing compact system design.

## The seal to atmosphere

is guaranteed by using the triple Viton-O-ring around the base of the shaft

## Lower torque ratings

enable the use of smaller, less expensive actuators to be used

## Extended shaft lining

ensures optimum media sealing also beyond the stem seal assembly

## A wide sealing face

prevents leakage at the flange

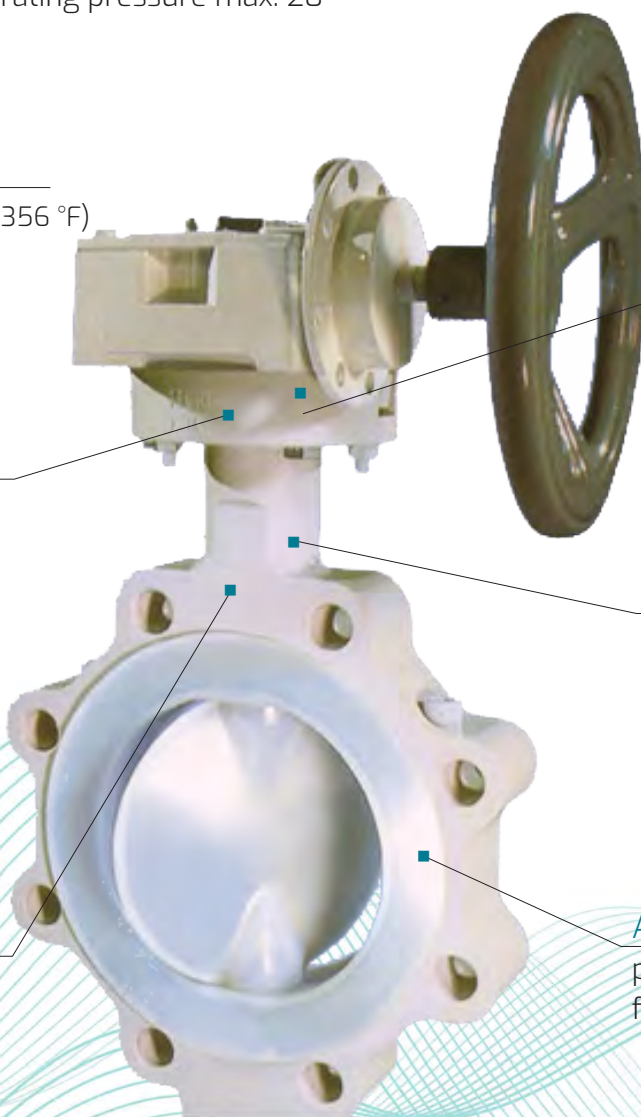

# Offshore Type Lined Butterfly Valve 108LAV

A cost effective solution for corrosive applications replacing expensive, high alloy valves



### Teflon liner

for the valve body in one piece (no joints)



### Triple Viton-O-ring seals

provide a second, third and fourth line of protection against atmospheric leakage.

### Blow-out proof design

Stem and disc are one part combined with the anti-blow-out system (API 609 compliant.)

### Seamless one piece liner

The PFA body lining is continuous from the wide flange face to far up the stem.

### In-line resilient seal assembly

ensures optimum pressure distribution of the body liner to the disc assembly, providing tight sealing under all operating conditions. The wider seal-band provides a broader sealing area.

### Fully lined bottom shaft

assures optimum corrosion resistance and eliminates a potential leakage path.

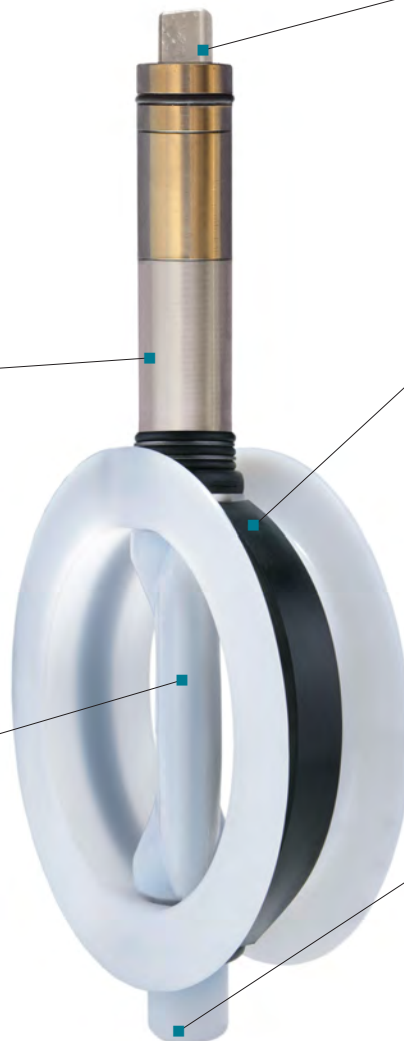

# 108LAV

## The robust design with the extended pressure range ensures a wide service area

108LAV is a Teflon® lined butterfly valve especially designed for seawater service offshore. It is fully rated to ANSI CL150 (19.6 bar) and is available in sizes 3" - 24". The valve is excellent for the following application areas:

- Sea water
- Firefighting system
- Ballast
- Cooling water systems
- Fresh water production
- Bilge
- Acid washing systems
- Produced water systems (seawater side, without sand)

### Design features:

For this Offshore Type Lined Butterfly Valve, bi-directional flow is possible at maximum operating pressure. Since the valve port corresponds to the piping diameter, a high flow capacity is guaranteed.

The seamless one piece molded liner together with the underlying elastic O-ring provides trouble- and maintenance-free operation. It covers the lower shaft completely and renders an additional sealing to atmosphere unnecessary.

The liner extends up the shaft to above the secondary seal. This sealing prevents leakage to atmosphere. The body seal ring is designed to provide a 360° sealing for in-line shutoff and at the upper and lower shaft to act as primary seal to atmosphere.

A further special feature is the one-piece disc consisting of a metallic core (disc/shaft) with a homogeneous non-porous plastic coating standing up to the secondary external seals.

All these features combined makes the XOMOX lined butterfly valve the solution for tight shutoff and corrosion resistance, and represent an advance on all previously available products of this type.

- Optimum operation under vacuum conditions
- Permanently tight closure
- Higher Cv values
- Normally used for on/off applications, but can also be used for throttling service

# Offshore Type Lined Butterfly Valve

## 108LAV

### Design standards and technical information

LUG design is standard for this valve. Bolt holes are drilled through and tapped according to Imperial units ANSI B1.1 (UNC). It is to be mounted between flanges, which are according to ANSI B16.5, RF. However, the valve can also be supplied with Lug holes tappet acc. to ISO 262 (metric) or Wafer style as an option.

Face to face dimensions (H1) are according to API609, Table A (14" Table B). The LUG style valve is being stocked in our facilities from 3" up to 12".

The valve is supplied according to various VDS in the Norsok and TR2000 systems. Contact GPA Flowsystem for further information if required.

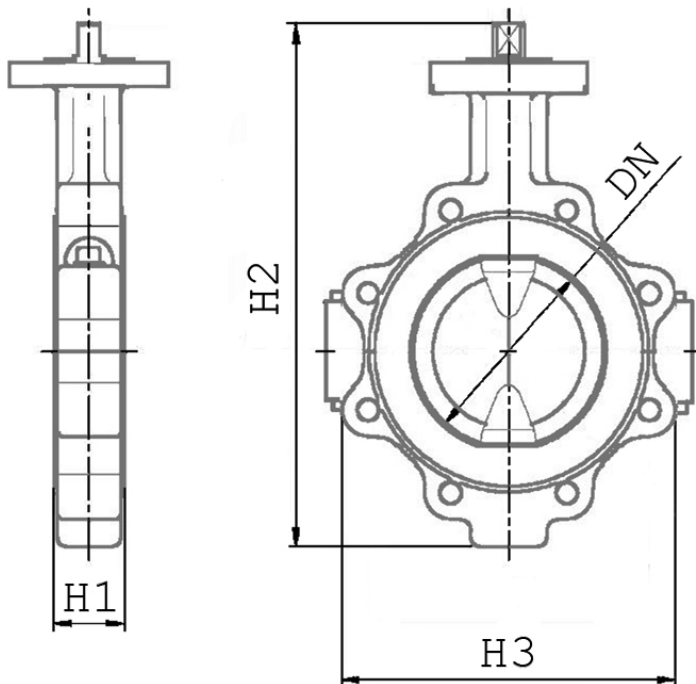

Size	Dimensions		
	NPS	H1	H2
3"	46	326	182
4"	52	360	210
6"	56	411	264
8"	60	480	327
10"	68	560	396
12"	78	594	467
14"	92	783	576
16"	102	828	640
18"	114	911	676
20"	127	1001	740
24"	154	1124	880

14"-24" contact for availability

Description	Material	Note
body	ASTM A395 / EN-JS1049	Ductile iron
disc / shaft core	1.6982 + QT (Grade GX3crNi13-4 +QT) / PFA/PTFE liner	Stainless steel
body-lining	PFA / PTFE	PFA 3"-12" / PTFE 14"-24"
triple-o-ring seal	Viton	Synthetic rubber
screws	ASTM A193-B8M2 / A470	Stainless steel
nuts	ASTM A194-8M / A4	Stainless steel

# 108LAV

## Tested and approved on several occasions

### Cycle test:

The XOMOX type 108LAV has successfully passed a cycle test, required and defined by Statoil. The test includes testing both sides of the valve with 21,6 bar differential pressure in 24 hours, 30 minutes and 15 minutes. In addition, 250 open/close cycles without pressure. During the test, measuring the leakage and breakaway torque, as well as opening the valve against pressure shall be done.

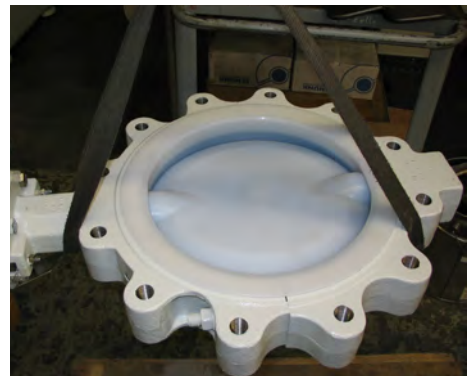

### Objective:

In sea water service lined butterfly valves are a cheaper alternative to conventional double/triple offset valves. However the working life for these valves can be very short if not properly designed and manufactured. The objective of this procedure is to ensure that the proposed valve design is fit for purpose.

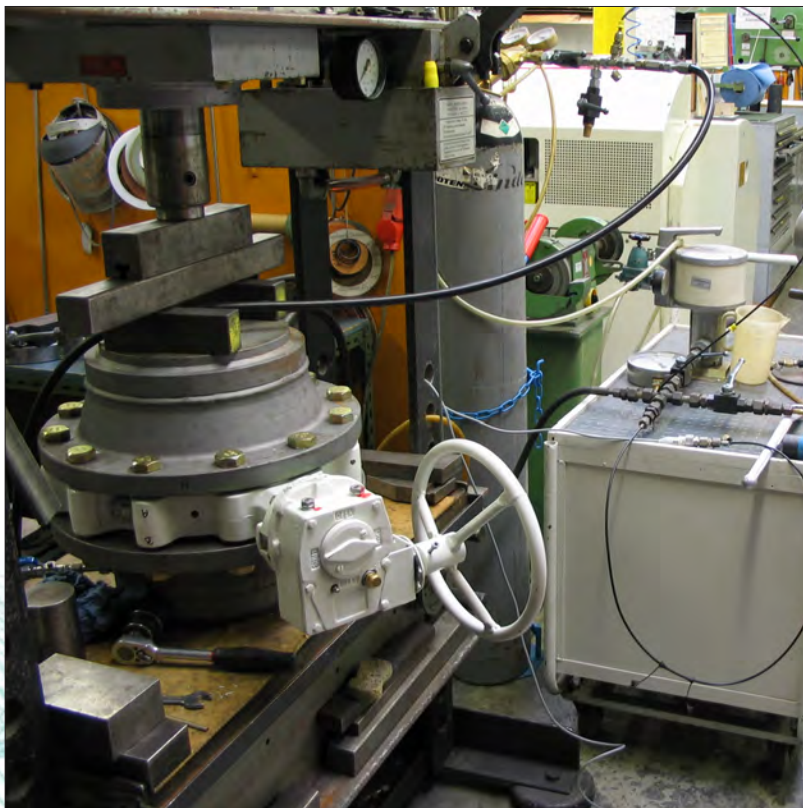

# Offshore Type Lined Butterfly Valve 108LAV

## Fire test

### Fire safe test:

The 108LAV valve has been through a fire safe test acc. API 607 4th edition, performed by XOMOX. Selected valve size was 8". After the test, the butterfly valve was cooled down abruptly with water. Two tests were performed; with and without metallic protection rings around raised face made from PFA.



- Both valves were still operable
- Both valves were tight at the shaft to atmosphere during and after the fire
- Both discs showed only little deformation after the test
- Internal leakage and leakage at the flanges were lower than 5% of valve kv-value

### Conclusion:

- The butterfly valves are suitable for usage in pipelines. Even then, if they are exposed to fire, the occurring leakages will not cause any further damages
- Metal protection rings at the flanges are not recommended by Xomox

## References

The valve has been supplied to a large number of platforms and FPSOs. Many of them have valves that have been operative for more than 10 years. Due to the valve's long lifetime, GPA has many references with valves in operation. Statoil is one of the companies who has been using this valve successfully for seawater service for many years. The feedback we get from the endusers is that they see it as a good alternative to valves in high alloy materials like Titanium and Super Duplex.

For specific references please contact GPA Flowsystem A/S.

## 108LAV

## Some other Teflon®-Lined products in our catalogue include:



### Lined Plug Valves

The 2-way and 3-way fully lined plug valves feature an encapsulated plug rotating in a fully lined body. Superior PFA lining economically handles the most corrosive fluids. Beneficial for use for dirty, aggressive fluids.



### Lined Check Valves

Lined Swing check, Ball check, Piston check and Poppet check valves have PFA as standard lining and use the cast dovetail recesses and machined grooves to lock the liner to the body casting.



### Lined Ball Valves

An economical solution for the vast majority of chemical applications while maintaining the highest possible degree of performance in terms of in-line leakage and fugitive emissions. Can be delivered fully rated ANSI CL150 in sizes 1/2" up to 4".



### XLD Lined Butterfly Valves

Among its benefits is its resistance to permeation which leads to an extension of product life and greater operator safety as it does not permit atmospheric leakage.



### Lined Accessories

We also deliver fully lined accessories like filters, dirt traps, sampling valves and PTFE-lined pipes and fittings.

### Resistoflex Lined Pipes and Fittings

We also deliver fully lined accessories like filters, dirt traps, sampling valves and PTFE-lined pipes and fittings.



# Offshore Type Lined Butterfly Valve 108LAV



# 108LAV





## HOVEDKONTOR

Regnbueveien 9  
NO-1405 Langhus  
Telefon: +47 64 85 68 00  
E-post: [info@gpa.no](mailto:info@gpa.no)