

M1FM

Kuleventil innv. gjenge

- PP-kuleventil
- Innvendig gjenge
- Håndtaket er utstyrt med sikkerhetslås og øye for TAG-merking/hengelås.
- Fast sete, en side av ventilen kan demonteres under fullt trykk.
- PN 10
- Setetetning i PTFE
- EPDM

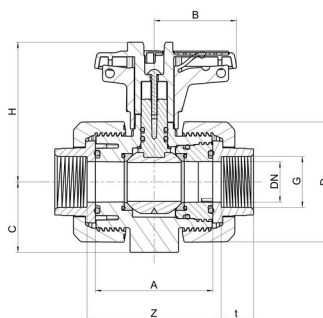

Artikkelnr	NRF	DN	Tetning smat.	G	A	B	C	D	H	t	Z
M1FM-E-R010		10	EPDM	3/8"	61.5	40	33	58	74.5	14.5	66.5
M1FM-E-R015	2446294	15	EPDM	1/2"	61.5	40	33	58	74.5	16	66.5
M1FM-E-R020	2446295	20	EPDM	3/4"	69	51.5	40	68.5	83	17.5	74
M1FM-E-R025	2446296	25	EPDM	1"	73	51.5	43.5	75.5	85.5	19.5	80
M1FM-E-R032	2446297	32	EPDM	1 1/4"	83	64	51	92	104.5	22	89
M1FM-E-R040	2446298	40	EPDM	1 1/2"	94	73	56.5	108	113	25.5	103
M1FM-E-R050	2446299	50	EPDM	2"	109	85	64.5	127.5	121.5	29	119
M1FM-V-R010		10	FPM	3/8"	61.5	40	33	58	74.5	14.5	66.5
M1FM-V-R015		15	FPM	1/2"	61.5	40	33	58	74.5	16	66.5
M1FM-V-R020		20	FPM	3/4"	69	51.5	40	68.5	83	17.5	74
M1FM-V-R025		25	FPM	1"	73	51.5	43.5	75.5	85.5	19.5	80
M1FM-V-R032		32	FPM	1 1/4"	83	64	51	92	104.5	22	89
M1FM-V-R040		40	FPM	1 1/2"	94	73	56.5	108	113	25.5	103
M1FM-V-R050		50	FPM	2"	109	85	64.5	127.5	121.5	29	119