

M11M

Kuleventil innv. sveis

- PP-kuleventil
- Innvendig sveis
- Håndtaket er utstyrt med sikkerhetslås og øye for TAG-merking/ hengelås.
- Fastsete, en side av ventilen kan demonteres under fullt trykk.
- Setetetning i PTFE
- PN 10
- EPDM

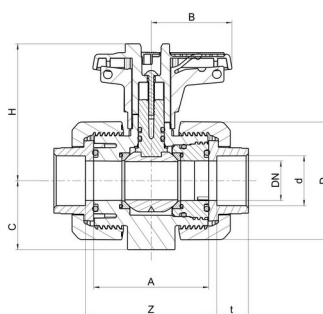

Artikkelnr	DN	d	Tetnings mat.	A	B	C	D	H	t	Z
M11M-E-016	10	16	EPDM	61.5	40	33	58	74.5	14.5	69.5
M11M-E-020	15	20	EPDM	61.5	40	33	58	74.5	16	66.5
M11M-E-025	20	25	EPDM	69	51.5	40	68.5	83	17.5	78
M11M-E-032	25	32	EPDM	73	51.5	43.5	75.5	85.5	19.5	84
M11M-E-040	32	40	EPDM	83	64	51	92	104.5	22	97
M11M-E-050	40	50	EPDM	94	73	56.5	108	113	25.5	114
M11M-E-063	50	63	EPDM	109	85	64.5	127.5	121.5	29	136.5
M11M-E-075	65	75	EPDM	131.5	110	85	160	151.5	34.5	162
M11M-E-090	80	90	EPDM	135.5	132	100	196.5	153	38.5	206.5
M11M-E-110	80	110	EPDM	135.5	132	100	196.5	153	42	207.5
M11M-V-016	10	16	FPM	61.5	40	33	58	74.5	14.5	69.5
M11M-V-020	15	20	FPM	61.5	40	33	58	74.5	16	66.5
M11M-V-025	20	25	FPM	69	51.5	40	68.5	83	17.5	78
M11M-V-032	25	32	FPM	73	51.5	43.5	75.5	85.5	19.5	84
M11M-V-040	32	40	FPM	83	64	51	92	104.5	22	97
M11M-V-050	40	50	FPM	94	73	56.5	108	113	25.5	114
M11M-V-063	50	63	FPM	109	85	64.5	127.5	121.5	29	136.5
M11M-V-075	65	75	FPM	131.5	110	85	160	151.5	34.5	162
M11M-V-090	80	90	FPM	156.5	132	100	196.5	167	38.5	206.5
M11M-V-110	80	110	FPM	156.5	132	100	196.5	167	42	207.5

Med forbehold om konstruksjonsendringer og tekniske endringer. Kan endres uten varsel.

gpa.no | info@gpa.no | +47 64 85 68 00