

T40U

Membranventil flenset DIN PN10/16 EPDM

- PVC-membranventil
- Håndtaket er utstyrt med sikkerhetslås og øye til hengelås.
- Flenset DIN PN10/16
- E=EPDM
- FPM på forespørsel

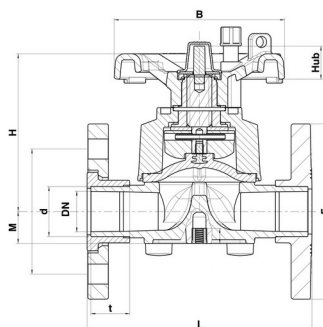

| Artikkelnr | d | DN | B | E | H | Hub | L | M |
|------------|-----|-----|-----|---------|-----|------|-----|-----------|
| T40U-E-020 | 20 | 15 | 86 | 95-97 | 100 | 9.0 | 130 | 16.5-17 |
| T40U-E-025 | 25 | 20 | 86 | 102-108 | 100 | 9.0 | 150 | 16.5-17 |
| T40U-E-032 | 32 | 25 | 86 | 114-125 | 107 | 11.0 | 160 | 20-21 |
| T40U-E-040 | 40 | 32 | 136 | 130-140 | 144 | 22.0 | 180 | 25.5-33 |
| T40U-E-050 | 50 | 40 | 136 | 133-151 | 144 | 22.0 | 200 | 32-33 |
| T40U-E-063 | 63 | 50 | 136 | 162-165 | 170 | 28.0 | 230 | 38.5-40.5 |
| T40U-E-075 | 75 | 65 | 234 | | 260 | 35.0 | 284 | 25 |
| T40U-E-090 | 90 | 80 | 234 | | 260 | 35.0 | 300 | 25 |
| T40U-E-110 | 110 | 100 | 234 | | 330 | 45.0 | 340 | 25 |
| T40U-P-020 | 20 | 15 | 86 | 95-97 | 100 | 9.0 | 130 | 16.5-17 |
| T40U-P-025 | 25 | 20 | 86 | 102-108 | 100 | 9.0 | 150 | 16.5-17 |
| T40U-P-032 | 32 | 25 | 86 | 114-125 | 107 | 11.0 | 160 | 20-21 |
| T40U-P-040 | 40 | 32 | 136 | 130-140 | 144 | 22.0 | 180 | 25.5-33 |
| T40U-P-050 | 50 | 40 | 136 | 133-151 | 144 | 22.0 | 200 | 32-33 |
| T40U-P-063 | 63 | 50 | 136 | 162-165 | 170 | 28.0 | 230 | 38.5-40.5 |
| T40U-P-075 | 75 | 65 | 234 | | 260 | 35.0 | 284 | 25 |
| T40U-P-090 | 90 | 80 | 234 | | 260 | 35.0 | 300 | 25 |
| T40U-P-110 | 110 | 100 | 234 | | 330 | 45.0 | 340 | 25 |